

Frequency	Rpm	Gross Engine Output Standby / Prime kWm (ps)	Net Engine Output Standby / Prime kWm (ps)	Emission
50 Hz	1500	78(104) / 70(94)	75(100) / 67(90)	Stage V (DOC+DPF)
60 Hz	1800	92(124) / 83(112)	88(118) / 79(105)	Tier 4 Final (DOC only)



◆ General Engine Data

• Engine Type	In-line, 4-cycle
• Number of cylinders	4
• Displacement	3,409 liter
• Bore x Stroke	98 x 113 mm
• Compression ratio	18.0 : 1
• Firing order	1 - 3 - 4 - 2
• Aspiration	Turbocharged and air-to-air aftercooled
• Combustion System	Direct injection
• Rotation	Counter clockwise viewed from Flywheel
• Clutch	SAE#3 - 11/5" / SAE#4 - 10" (SAE J620)
• Dry weight	464 kg (with aftertreatment) 564 kg (with powerpack)
• Valve System Type	Over head valve
• Number of Valves	Intake 2, exhaust 2 per cylinder Hydraulic Valve Lash Adjust

◆ Engineering Data

• Water flow	75 liters/min @1,500 rpm 90 liters/min @1,800 rpm
• Heat rejection	- to coolant 11.3 kcal/sec @1,500 rpm 12.9 kcal/sec @1,800 rpm - to CAC 2.7 kcal/sec @1,500 rpm 3.6 kcal/sec @1,800 rpm
• Air flow	5,210 liter/min @1,500 rpm 6,150 liter/min @1,800 rpm
• Exhaust gas temp	750 °C ↓ @1,500 rpm & 1800 rpm
• Max. permission restrictions	- Intake system 3.0 kPa clean filter 6.5 kPa dirty filter - Exhaust system 50 kPa max.

◆ Electrical System

• Alternator	12V x 110A
• Voltage Regulator	Built-in type IC regulator
• Starting Motor	12V x 2.5kW
• Battery Voltage	12V
• Battery Capacity	100 Ah, 750CCA (recommended)
• Starting Aid	Glow plug

◆ Cooling System

• Cooling method	Fresh water forced circulation
• Water capacity	4.7 liter (engine only) 12.1 liter (with powerpack)
• Water pump	Centrifugal type driven by belt
• Cooling fan	Blower type, Ø460 (ATB 52°C)
• Water temperature	110°C (max.)

◆ Fuel System

• Injection pump	Bosch Common-rail Pump
• Governor	Controlled by ECU
• Fuel filter	Full flow, cartridge type
• Used fuel	Diesel fuel only
• Diesel consumption	204 g/kWh @1,500 rpm 206 g/kWh @1,800 rpm
• DEF Consumption	7~8% of Diesel consumption

◆ Lubrication System

• Oil filter	Full flow, cartridge type
• Oil pan capacity	High level 12.6 liters Low level 6.0 liters
• Angularity limit	35 deg all around
• Lubrication oil	10W30/40(API CJ-4 / ACEA E6, E9)
• Maximum oil temp	135°C at main oil gallery
• Lub oil pressure	Idle Speed : Min 100 kPa

◆ Engine Dimension

- Dimension (L×W×H) 936 × 690 × 1,140 mm (engine only)

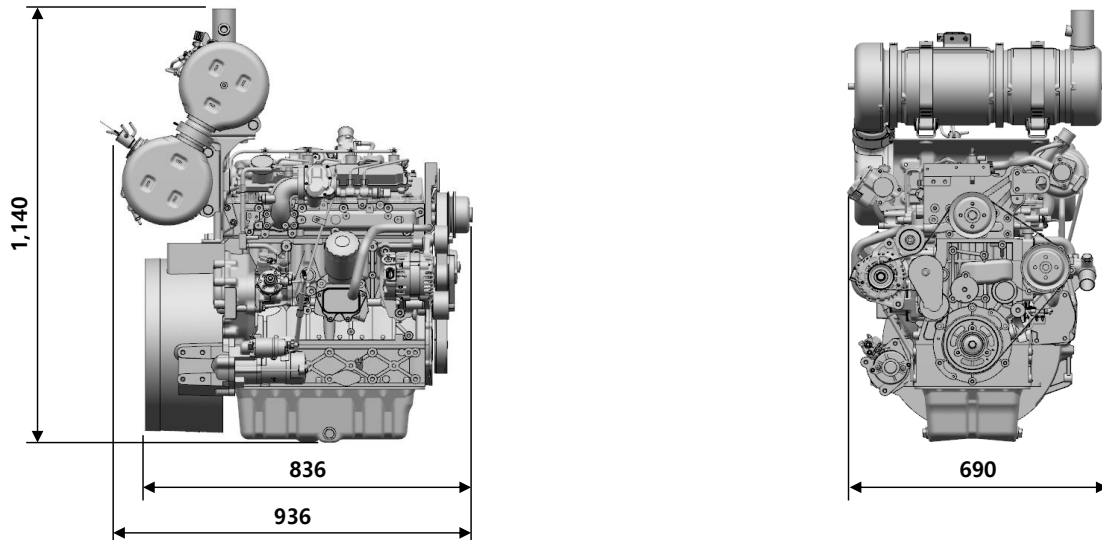

- Dimension (L×W×H) 1,276 × 736 × 1,181 mm (with power pack)

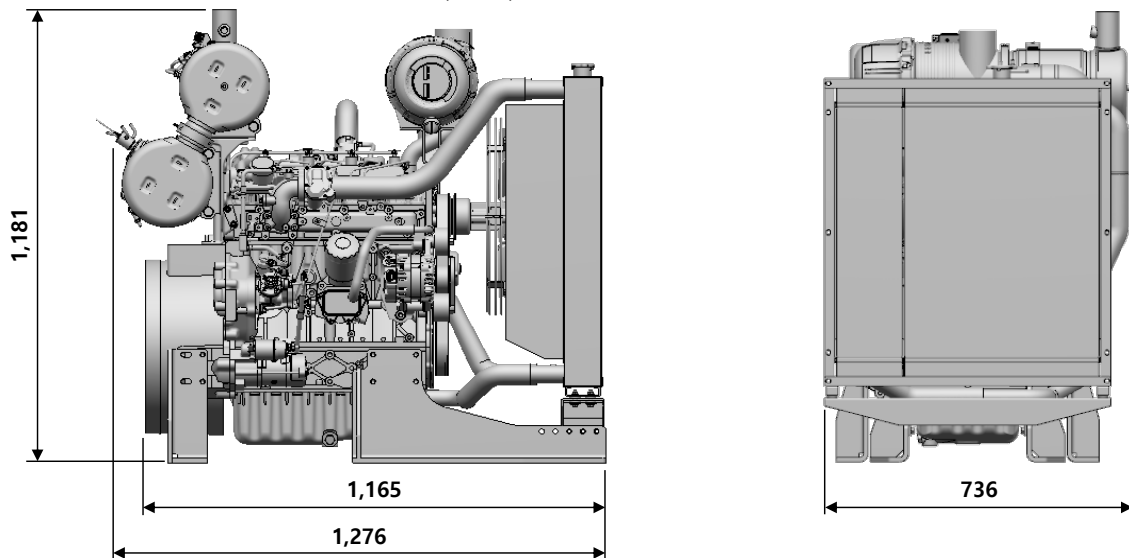

Ratings Definitions

The power ratings of Emergency Standby and Prime are in accordance with ISO 8528.

Fuel Stop power in accordance with ISO 3046.

Electric power (kWe) must be considered cooling fan loss, alternator efficiency, altitude derating and ambient temperature.

STANDBY POWER RATING is applicable for supplying emergency power for the duration of the utility power outage.

No overload capability is available for this rating. A standby rated engine should be sized for a maximum of an 80% average load factor and 200 hours of operation per year. This includes less than 25 hours per year at the Standby Power rating.

PRIME POWER RATING is available for an unlimited number of hours per year in variable load application. Variable load should not exceed a 70% average of the Prime Power rating during any operating period of 24 hours. The Total operating time at 100% Prime Power shall not exceed 500 hours per year. A 10% overload capability is available for a period of 1 hour withing a 12 hour period of operation. Total operating time at the 10% overload power shall not exceed 25 hours per year.

◆ Conversion Table

in. = mm x 0.0394	hp = PS x 0.98635	kW = 0.2388 kcal/s
PS = kW x 1.3596	lb = kg x 2.20462	lb/PS.h = g/kW.h x 0.00162
psi = kg/cm ² x 14.2233	lb/ft = N.m x 0.737	cfm = m ³ /min x 35.336
in ³ = lit. x 61.02	U.S. gal = lit. x 0.264	

Powered by
Innovation

※Specifications are subject to change without prior notice.