

Frequency	rpm	Net Power Output (kWm)		Emission
		Standby	Prime	
50 Hz	1500	47.5	45.2	Stage V (DOC+DPF)
60 Hz	1800	54.0	48.5	
50 Hz	1500	41.5	38.7	Tier 4 Final (DOC only)
60 Hz	1800	49.0	45.3	



Ratings Definitions

The power ratings of Emergency Standby and Prime are in accordance with ISO 8528. Electric power (kWe) must be considered cooling fan loss, alternator efficiency, altitude derating and ambient temperature.

STANDBY POWER RATING is applicable for supplying emergency power for the duration of the utility power outage. No overload capability is available for this rating. A standby rated engine should be sized for a maximum of an 80% average load factor and 200 hours of operation per year. This includes less than 25 hours per year at the Standby Power rating.

PRIME POWER RATING is available for an unlimited number of hours per year in variable load application. Variable load should not exceed a 70% average of the Prime Power rating during any operating period of 24 hours. The Total operating time at 100% Prime Power shall not exceed 500 hours per year. A 5% overload capability is available for a period of 1 hour withing a 12 hour period of operation. Total operating time at the 5% overload power shall not exceed 25 hours per year.

◆ GENERAL DATA

• Engine model	DM02VP (StageV) / DM02PP (Tier4F)
• Engine type	4-Cycle and 4-Cylinder Diesel
• Aspiration	Turbocharged and air-to-air aftercooled
• Bore x Stroke	90 x 94 mm
• Displacement	2.392 liter
• Compression ratio	17.0 : 1
• Rotation	Counter clockwise viewed from Flywheel
• Firing order	1 - 3 - 4 - 2
• Dry weight	266 kg (with after-treatment)
• Flywheel and Housing	SAE #4 - 10" / SAE #3 - 11.5" (SAE J620)

◆ COOLING SYSTEM

• Cooling method	Fresh water forced circulation
• Coolant capacity	3.8 liters (engine only) / 9.3 liters (with powerpack)
• Opening pressure of pressure cap	0.9 bar
• Maximum water temperature for Standby and Prime	110°C
• Water pump	Centrifugal type driven by belt
• Thermostat type and range	Wax-pellet type
• Cooling fan	Blower type, Plastic, Ø440, 6 blade
• Max external coolant system restriction	Not Available

◆ FUEL SYSTEM

• Injection pump	Bosch Common-rail Pump
• Governor	Controlled by ECU
• Feed pump	Mechanical Transfer Pump
• Injection nozzle	Multi hole type
• Fuel filter	Full flow, cartridge type
• Frequency regulation, steady state	±0.5%

• Allowable fuel inlet restriction	0.5 ~ 1.5 bar
• Maximum fuel return restriction	1.2 bar
• Used fuel	Ultra-Low Sulfur Diesel (15ppm Sulfur Maximum)

◆ LUBRICATION SYSTEM

• Lubricant method	Fully forced pressure feed type
• Oil pump	Gear type driven by crankshaft
• Oil filter type	Full flow, cartridge type
• Oil pan capacity	Max. 8.6 liters, Min. 4.5 liters
• Lubricant oil pressure	Idle Speed : Min 100 kPa Governed Speed : Min 250 kPa
• Maximum oil temperature	135°C at main oil gallery
• Angularity limit	35 deg all around
• Lubrication oil	10W30/40 (API CJ-4 / ACEA E9)

◆ ELECTRICAL SYSTEM

• Voltage regulator	Built-in type IC regulator
• Battery voltage	12V
• Battery charging alternator	12V x 110A
• Battery capacity	100 Ah, 750CCA (recommended)
• Starting motor	12V x 2.5kW
• Starting aid	Glow plug, Fuel heater

◆ VALVE SYSTEM

• Valve system type	Over head valve
• Number of valves	Intake 2, exhaust 2 per cylinder
• Valve Lashes and timing	Hydraulic Valve Lash Adjust (Maintenance Free)

◆ PERFORMANCE DATA

		Standby Power		Prime Power		
		Stage V	Tier4F	Stage V	Tier4F	
• Emission						
• Governed engine speed	rpm	1500	1800	1500	1800	
• Engine idle speed	rpm	800	800	800	800	
• DPF regeneration speed	rpm	1500	-	1500	-	
• Gross power output	kWm	48.1	50.0	45.8	46.4	
• Break mean effective pressure	Mpa	1.8	1.8	1.6	1.6	
• Specific fuel consumption						
	25% load	liters/hr	3.2	3.8	3.2	3.5
	50% load	liters/hr	6.0	6.9	5.7	6.2
	75% load	liters/hr	8.9	10.3	8.4	9.1
	100% load	liters/hr	12.1	13.8	11.3	12.2
• Sound pressure at 1m from the each side						
	Engine	dB(A)	85.6	88.7	85.4	88.6
	Cooling fan	dB(A)	72.1	79.9	72.1	79.9

All data and the specific fuel consumption are based on ISO 8528, Standard reference conditions are in accordance with 298 K (25° Celsius) air temperature, 100 kPa(1,000 mbar) air pressure, 60% relative humidity, 110m(361ft) altitude.

Operation at Elevated Temperature and Altitude :

In high altitude conditions of over 3,000m, torque will be gradually reduced without a fault code.

◆ ENGINE DIMENSION

- Dimension (L×W×H) : 857 × 576 × 724 mm

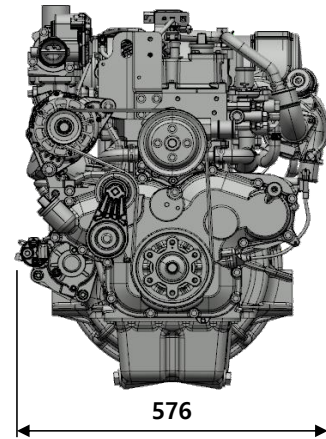
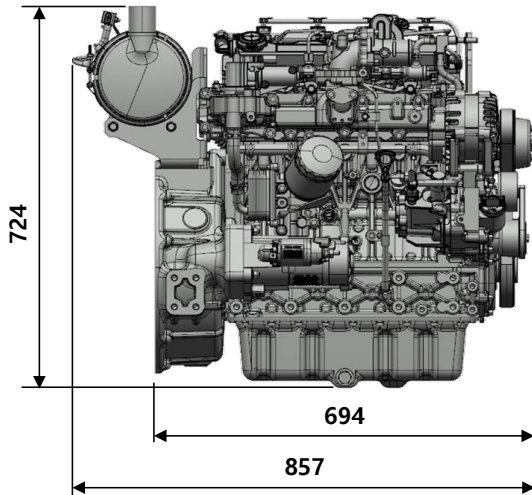

- Dimension (L×W×H) : 1,185 × 629 × 959 mm

